

3. GN1 Wiring diagram

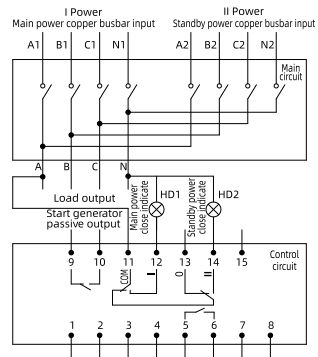

4. GA Split type Wiring and usage method of auxiliary terminals

The phase sequence of main power A/B/C/N input and standby power A/B/C/N input must maintain consistency.

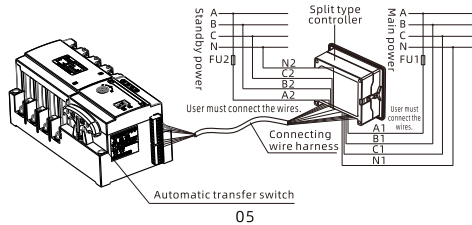

I. Overview

This series of Automatic Transfer Switching Equipment(ATSE) is suitable for the automatic transfer between two power sources in emergency power supply systems with AC rated working voltage of AC400V and below, rated frequency of 50Hz, and rated current ranging from 16A to 125A to ensures the continuous, safe, and reliable operation of important loads (such as fire protection loads). It is widely used in important places where power outages are not allowed, such as hospitals, shopping malls, banks, chemical plants, high-rise buildings, and fire protection facilities.

II. Functions and Features

1. It has the functions of automatic conversion for under-voltage, over-voltage and phase loss. (GN1 has the functions of under-voltage and phase loss conversion. GA1 products have phase loss conversion functions for phase C and phase N.)
2. The main circuit adopts a double-break point horizontal pull structure, ensuring reliable disconnection and disconnection.
3. It complies with the requirements of the disconnector standard. With clear on-off position indication and lockable. Reliably achieving the isolation function.
4. It has a disconnect position (simultaneously disconnecting both the main and standby power supplies) to meet the requirements of fire linkage.

III. Normal Working Conditions

- The operating ambient temperature range is -5°C to +40°C, with an average temperature value within 24 hours not exceeding +35°C. The storage ambient temperature range is -25°C to +55°C, which can reach +70°C shortly (within 24 hours).
- The altitude of the installation site should not exceed 2000m.
- The relative humidity of the air at the installation site should not exceed 50% when the ambient temperature is +40°C. At lower temperatures, a higher relative humidity is acceptable. For example, when the average minimum temperature of the wettest month is +20°C, the average maximum relative humidity of that month can reach 90%. Appropriate measures should be taken to prevent condensation caused by temperature changes.
- Pollution Degree 3 (conductive pollution or non-conductive pollution becoming conductive due to condensation).
- ATSE can be installed vertically or horizontally in the cabinet. For special installation requirements, please contact With our company.
- The shell protection class of the product is IP20.
- Overvoltage Category:
 - Main circuit - Category III
 - Control and auxiliary circuits - Category II.

5. GA usage method of remote control type switch wiring terminals

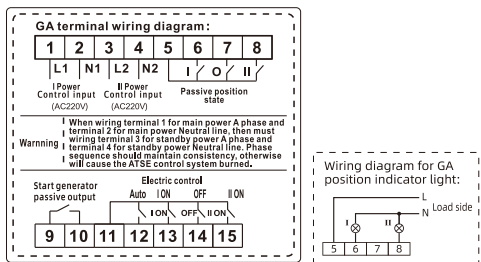

Note: For detailed information on the functions of the controller and the terminals, please refer to the corresponding controller manual instruction.

6. GA1 usage method of economic type auxiliary terminals

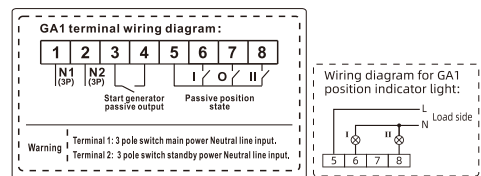

- Terminal 1: 3 pole switch main power Neutral line input. Terminal 2: 3 pole switch standby power Neutral line input.
- Terminal 3-4: Start generator passive output. Connect this port to the generator controller to achieve automatic start generator control.
- Terminal 5-6: Main power close passive position feedback. Terminal 5-7: Double-break passive position feedback. Terminal 5-8: Standby power close passive position feedback.

IV. Type and Meaning

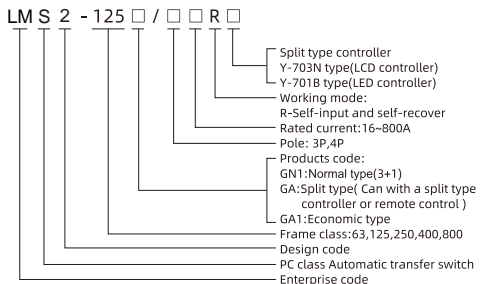

V. Main Technical Parameters

Frame class	63						125						250						400						800					
Rated current (IEA)	16	20	25	32	40	50	63	80	100	125	160	200	225	250	315	350	400	630	800											
Rated insulation voltage Ui	800V												1000V																	
Control voltage Us	AC230V 50Hz																													
Rated impulse withstand voltage Uimp	8kV												12kV																	
Rated working voltage Ue	AC400V 50Hz																													
Using category	AC-33B												AC-33B																	
Rated short-circuit making capacity Icm	7.65kA						17kA						32kA																	
Rated short-time withstand current Ikt	5kA/30ms						10kA/30ms						10kA/60ms						16kA/60ms											
Transfer Time	<2s																													
Protection level	IP20(except for terminals)																													

VIII. Copper Busbar Dimensions

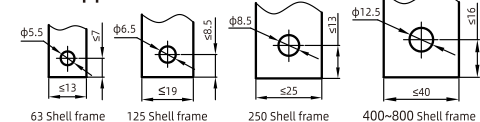

IX. Correct Installation Method Of The Switch

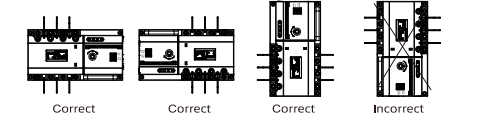

X. Switch Commissioning Instructions

1. All work related to the installation and commissioning of the product should be performed by professionals who are familiar with this switchgear.
2. Before commissioning, consider appropriate protective and preventive measures. The wiring of the switch's main circuit must be such that the leads are not subjected to any pressure or force.
3. Before commissioning, inspect the switch for damage or any other hazardous environmental influences, and check for loose wire ends caused during transportation. Clean dirt, especially on the surface of insulating parts.
4. When connecting the primary circuit, ensure that the phase sequence of the main and standby power sources is consistent. When connecting the secondary control circuit, strictly follow the instructions in this manual. The switch must be grounded properly during installation.
5. After installing the product, without powering it on, take out the dedicated operating handle provided with the product, transfer it from normal to standby, and then from standby to normal for three cycles. The product should operate flexibly.
6. Check the primary wiring and secondary circuit, and after confirming that there are no errors, position the product in the normal position, connect both the normal and standby power sources, then disconnect the normal power source. The product should switch to the standby power source after a delay. Restore the normal power source, and after another delay, it should return to the normal power source (except for self-transfer non-self-restore types). Perform three cycles, with each interval being more than 20s.

XI. Ordering Instructions

1. When ordering, users should specify the product's model, current specification, pole number, and other information.
2. If there are special installation conditions, users must provide corresponding technical information or consult with our company.

Suggest sending the manual to the final user!
No. XZS2GHNE2604802

VI. Outline and Installation Dimensions

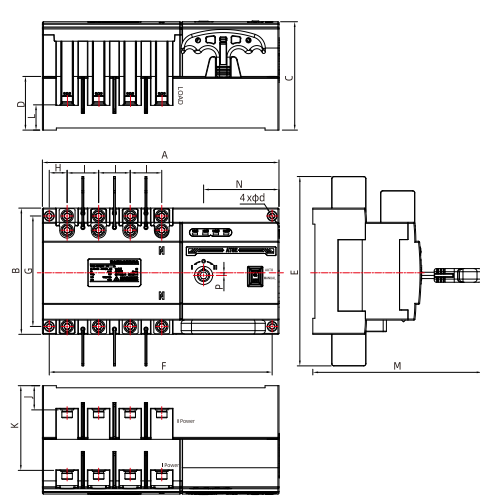

Specification	Outline and installation dimensions															
	A	B	C	D	E	F	G	H	I	J	K	L	φd	M	N	P
63A	185	110	975	47	170	172	95	14	22	17	75.5	19	4.5	156	68	2
125A	225	120	103	51	180	212	105	17	30	22	80.5	24	4.5	161	72	2.5
250A	310	185	140	72.5	282	285	160	40	45	32	111.7	35	6.5	203	85.5	6.5
400A	385	240	204.5	102.5	344	357	209	36	60	43	163	43	8.5	273.5	90.5	3
800A	385	240	204.5	102.5	344	357	209	36	60	45	163	45	8.5	273.5	90.5	3

When installing and using, pay attention to personal safety, and read the manual carefully!

Automatic Transfer Switching Manual Instruction



VII. Operating Instructions

1. GN1/GA/GA1 Panel description

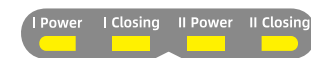

Indicator lights instruction

- I Power Indicator Light: Lights up when the main power three-phase voltage is normal. Turns off when there is a phase loss.
- II Power Indicator Light: Lights up when the standby power single-phase voltage (A phase and N phase) is normal. Turns off when there is a phase loss in A phase or N phase.
- I Power Close Indicator Light: Lights up when the main power source is closed.
- II Power Close Indicator Light: Lights up when the standby power source is closed. When the switch is in the double-break position, both the normal close indicator light and the standby close indicator light are off.

2. GN1 Usage method of normal type auxiliary terminals

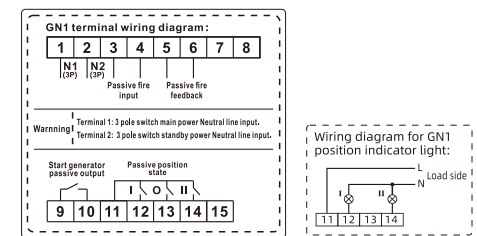

- Terminal 1: 3 pole switch main power Neutral line input.
- Terminal 2: 3 pole switch standby power Neutral line input.
- Terminal 3-4: Passive fire input. When connect terminal 3 and terminal 4 together, ATSE will transfer to double-break position.
- Terminal 5-6: Passive fire feedback output.
- Terminal 9-10: Start generator passive output. Connect this port to the generator controller to achieve automatic start generator control.
- Terminal 11-12: Main power close passive position feedback. Terminal 11-13: Double-break passive position feedback. Terminal 11-14: Standby power close passive position feedback.