

<When installing and using, pay attention to personal safety, and please read the manual carefully>

## **Automatic Transfer Switch Instruction Book**



It is recommended to send the manual to the end user  
No.ZXS1LA(LA)EN20062909

## I.General

Automatic transfer switch is a high-tech product developed by our company, Comply with GB/T14048.11Standards, also in line with 《Fire Protection Code for High-Rise Civil Buildings》, 《Emergency Lighting Design Guidelines》 etc.The parts and components of the product have undergone strict aging and screening. The finished product has been energized and aged at a continuous high temperature for 24 hours, and finally passed the loading inspection before leaving the factory. Thus ensuring the reliability and safety of the product .

Suitable for AC 400V and below, rated frequency 50Hz. In the power supply, there is phase loss, overvoltage, Under the control of the controller, the transfer switch can quickly change the load from the common power supply to the backup power supply (the backup power supply must be normal at this time) in the case of fault conditions such as undervoltage. The user can also put the load in an intermediate position when needed, so that the load is neither connected to the normal power supply nor to the standby power supply.

This product is mainly used for the primary and secondary loads specified by the state, and is widely used in fire-fighting, post and telecommunications Information, hospitals, hotels, urban rail transit, high-rise buildings, industrial assembly lines, television stations, etc. Places with continuous power supply. Commonly power sources can be power grids, self-starting generator sets, battery packs, etc.

Remark :

Two-stage automatic transfer switch, when the switch receives the transfer signal, it will switch from one power supply to another without stopping in the middle off position.

Three-stage automatic transfer switch. After the switch receives the transfer signal, it can be switched from one power supply to another power supply immediately (or after a preset delay time), Also It can be switched from a power supply to an intermediate disconnected position that is not connected to any power supply.

## II.Working Conditions

- Ambient air temperature: ambient temperature  $-5^{\circ}\text{C}$  to  $+40^{\circ}\text{C}$ , and the 24-hour average temperature value does not exceed Over  $+35^{\circ}\text{C}$ . Users whose ambient air temperature is higher than  $+40^{\circ}\text{C}$  or lower than  $-5^{\circ}\text{C}$  should consult with the manufacturer.
- The highest temperature of atmospheric humidity: when the degree is  $+40^{\circ}\text{C}$ , the relative humidity does not exceed 50%, and the maximum relative humidity per month Degree 90%, resistant to the influence of humid air on the sea, and can allow higher relative humidity at lower temperatures , special measures should be taken for the occasional condensation caused by temperature changes.
- Installation altitude: The altitude of the installation site does not exceed 2000 meters. When used at higher altitudes, the dielectric strength and cooling effect of the air should be considered to be reduced, please consult with the manufacturer.
- Pollution level: The environmental pollution level of the installation site is level 3 .
- Installation category: IV .
- Installation inclination: the product is fixedly installed in the cabinet, the maximum inclination is  $\pm 22.5^{\circ}$  .
- Arcing distance: The arcing distance is 30mm when AC 400V. The arcing distance when AC 690V is 60mm.

### III. Model And Meaning

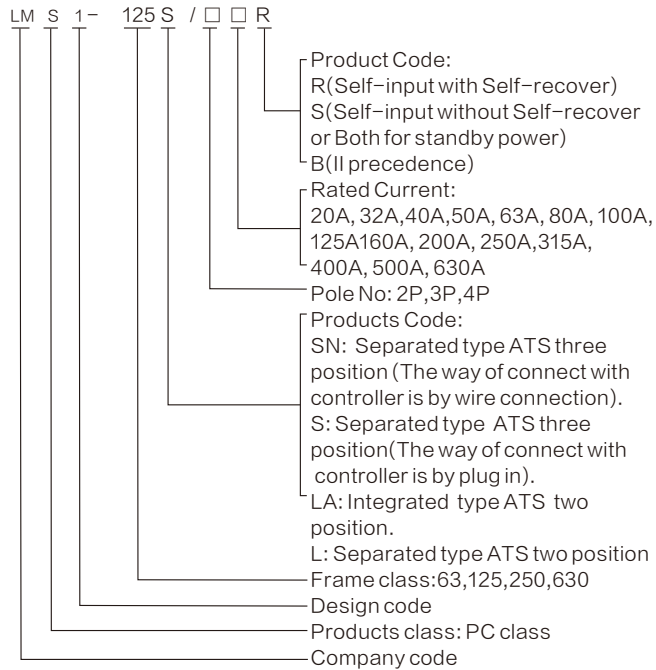

**Notice:**

1. Separated type ATS can be chose Y-701(LED) or Y-702(LCD) Controller .
2. ATS without output signal to start generator, Y-701 and Y-702 controller with it.
3. Working mode depends on the setting of controller, two position LA type ATS only available for self-input and self-recover.

### IV. Technology Parameter

Mode	SN Type, S Type, LA Type, L Type											
Insulation voltage	AC690V											
Rated voltage	400V											
Rated current	20A ~ 125A			160A ~ 250A			315A ~ 630A					
Rated impulse withstand voltage	8kV											
Kind of throw	Double throw											
Wiring method	Front board											
Number of pole	2P	3P	4P	2P	3P	4P	2P	3P	4P			
Weight	6	6.3	7	6	8	10	11	13.6	16.2			
Rated control power current	AC100V/110V	3	3	4	3	4	5	5	7			
	AC200V/220V	1.5	1.5	2	1.5	2	2.5	2.5	3			
Performance	Short-time resistance current	10kA										
	Through to breaking capacity	17kA										
	Transfer time	A Power	Input	80ms			80ms			100ms		
			Break	30ms			30ms			30ms		
	Transfer time	B Power	Input	100ms			100ms			120ms		
			Break	30ms			30ms			30ms		
	Electrical Life/ Mechanical Life	1000/5000						1000/4000				
Operating cycle	60times/hour											
Use type	AC-33iB											
Auxiliary switch ( Optional )	A、 B power source side are both 2 normal open, 2 normal closed, switch capability 15A/AC250V											
Accessories	Manual handle											

**Notice :**

The weight, Short time current, operate current and trip current are all for reference.

## V. Wiring Diagram

- Connecting drawing of YES1-S with Y-701 and Y-702  
(Please read the Controller Manual for further details.)

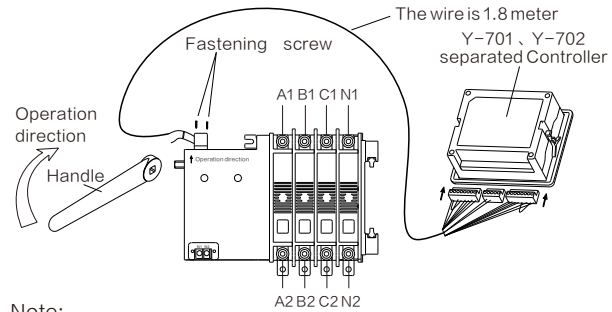

Note:  
N1 is neutral of Main Power, N2 is neutral of Standby Power.  
3 poles ATS need to connect with neutral line, 4Poles ATS can connect without neutral line.

- The drawing of YES1-SN with Y-701 and Y-702  
(Please read the Controller Manual for further details.)

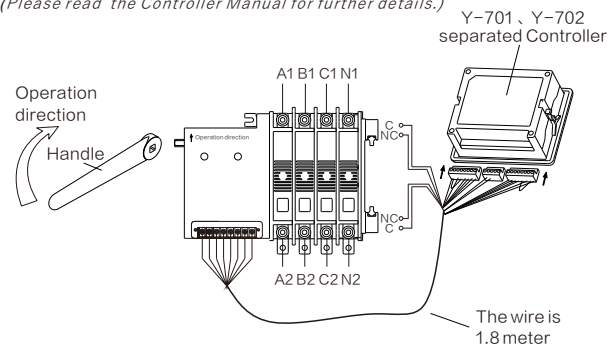

05

- The drawing of YES1-L with Y-701 and Y-702  
(Please read the Controller Manual for further details.)

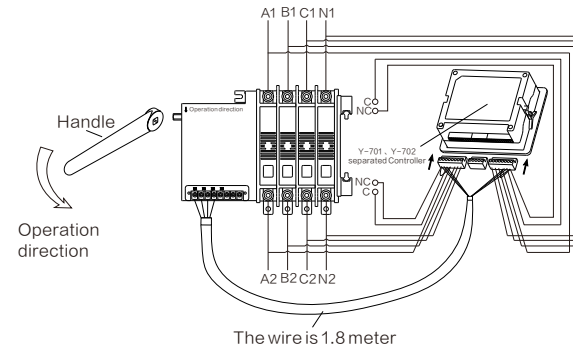

- The simple drawing of YES1-L with Y-701 and Y-702

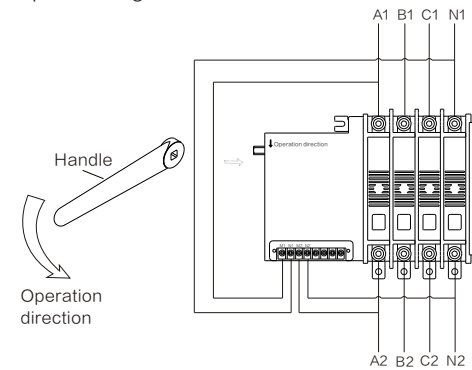

06

□ Schematic diagram of LA type simple wiring

**⚠** Note: When the main power used A1 phase and the standby A2 phase are connected to the power source, they must be the same phase power source. This product is only suitable for use from the grid to the grid.

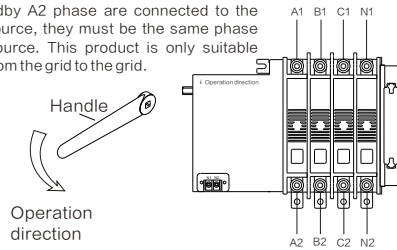

□ S, SN, LA, L type power supply indication, closing indication wiring diagram

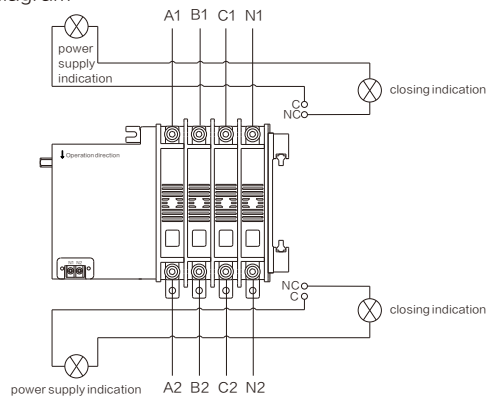

□ SN, L wiring diagram

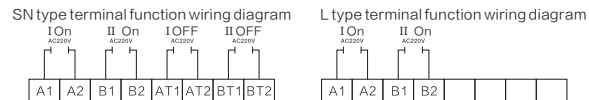

07

## VI. Shape and installation dimensions

Switch panel safety distance size: 30mm(400V),60mm(690V)

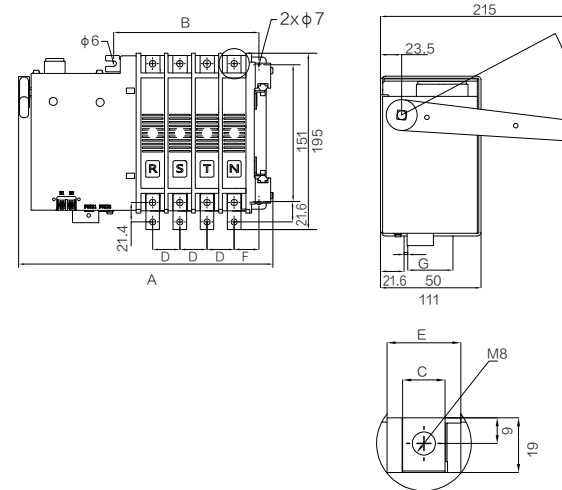

Model	Size Pole	A	B	C	D	E	F	G
		63SN,63S 63LA,63L	2P					
	3P	225	111					
	4P	245	131					
125SN,125S 125LA,125L	2P	223	100	15	30	26	27.5	4
	3P	253	130					
	4P	283	160					
250SN,250S 250LA,250L	2P	231	111	20	35	31	30	4
	3P	266	146					
	4P	301	181					

08

Switch panel safety distance size: 30mm(400V),60mm(690V)

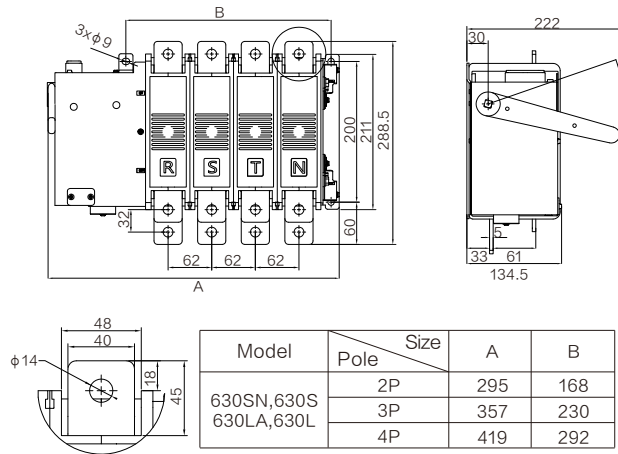

## VII. Manual operation method and Notes.

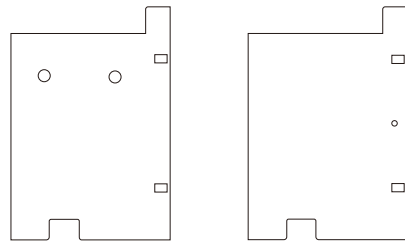

S、SN type three position LA、L type two position

09

- Main power input methods: Use a screwdriver to press the "two power supply cut off" (as shown in the figure) to make the main and standby power is in the OFF position (LA, L type two-position type does not need this operation), rotate the manual shaft in the direction indicated by the arrow with the handle, so that I power can always be set to the ON position.
- Standby power input methods: Use a screwdriver to press the "two power supply cut off" (as shown in the figure) to make the main and standby power is in the OFF position (LA, L type two-position type does not need this operation), Then press "Guide II Standby" and hold it, and at the same time turn the manual shaft in the direction indicated by the arrow to put the II power in the ON position.
- Manual trip method: (Only applicable to S and SN three-position models, LA and L two-position models can only be converted but not tripped) In order to ensure safety, In the power-off state, please insert a screwdriver into the left "two power supply cut-off" hole on the left and press inward to release it (please use the ON/OFF indicator to confirm whether the switch has tripped).

Note: Manual operation is prohibited when the switch is loaded. The controller must be in manual or power-off state during manual

## IX. Maintenance and storage

Inspection and maintenance must be carried out by professionals. All external power supplies should be cut off during inspection and maintenance. In order to maintain the performance of the power switch and keep it in good condition, the first maintenance inspection shall be carried out within one year after installation, and regular maintenance shall be done at least once a year thereafter.